

LIFTING POWER FOR THE FUTURE

TRUCK CRANES FOR RECYCLING AND TIMBER HAULAGE

Issue 5, April 2019





THE NEW GENERATION OF TRUCK CRANES HAS ARRIVED

Our new programme for truck cranes has been completed and has been developed for both transport and materials handling. The cranes have been specially produced for trucks and consist of modern, tried-and-tested technologies and world-class hydraulics. In our development work we have focussed on the operator, contractors and the environment. We have put great emphasis into class-leading driving properties, performance, high productivity and sustainability.

Cranab's extensive, solid crane-building experience is your guarantee of quality, development and long-term investment. Each of our cranes is manufactured with precision and is tested in tough Nordic climatic conditions to suit professional users.

This is Swedish quality from VindelIn at its best.





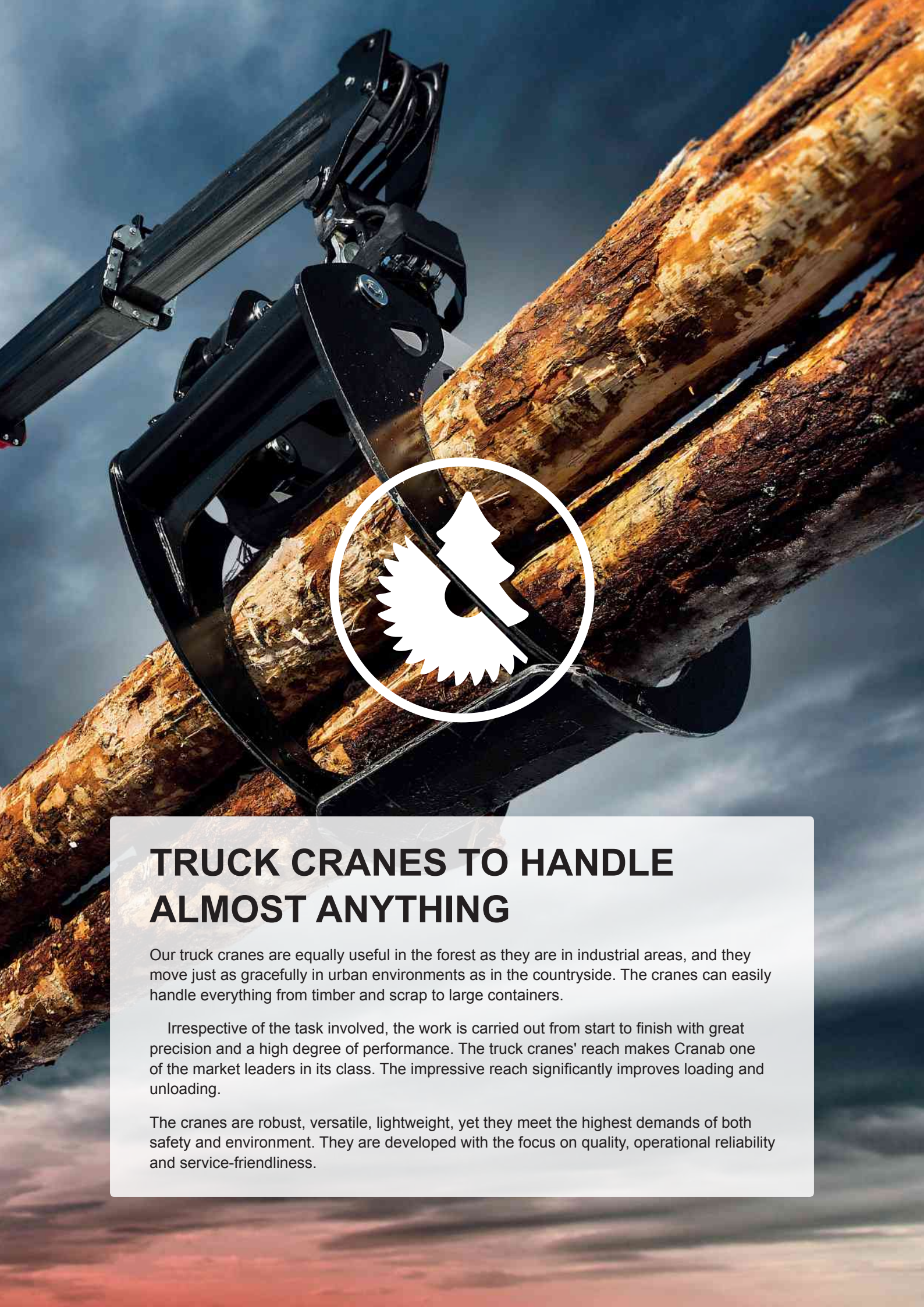

TRUCK CRANES TO HANDLE ALMOST ANYTHING

Our truck cranes are equally useful in the forest as they are in industrial areas, and they move just as gracefully in urban environments as in the countryside. The cranes can easily handle everything from timber and scrap to large containers.

Irrespective of the task involved, the work is carried out from start to finish with great precision and a high degree of performance. The truck cranes' reach makes Cranab one of the market leaders in its class. The impressive reach significantly improves loading and unloading.

The cranes are robust, versatile, lightweight, yet they meet the highest demands of both safety and environment. They are developed with the focus on quality, operational reliability and service-friendliness.

CRANAB TL12

Cranab's L-formed truck crane always puts you one step ahead: It is powerful, versatile and flexible, service-friendly and safe. The L-crane always comes fitted with a torque linkage, which makes it extra powerful and dependable, especially in deep lifting scenarios. Just like the Z-crane it features internal piping and hose routings as standard.



1. TORQUE LINKAGE. Link between the pillar and boom for increased power in all situations. The power link means uniform movement and speed right across the working range, enabling good operating characteristics.

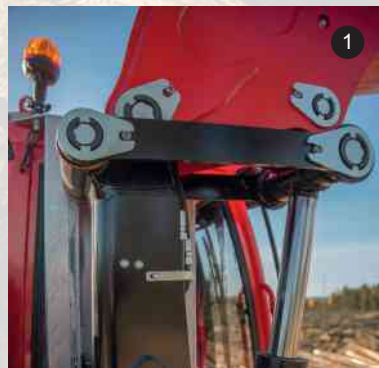

2. INTERNAL ROUTING. Hoses and pipes protected through internal routing throughout the boom system. Slide blocks adjustable from outside the boom. Adjustments are easily made from the outside using an Allen key to make the crane steady and stable.

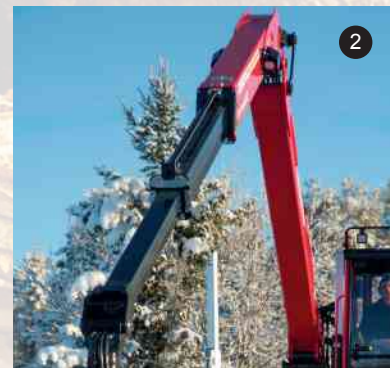

3. LEADING REACH. Cranab is one of few manufacturers able to offer a full 10 metre reach.



CRANAB TZ12

With Cranab's Z-crane you will achieve high productivity from the outset. The crane extends quickly and enables efficient production using extensively tested hydraulics and leading operating properties. Thanks to its compact design and the Z-crane's unique parking position you are able to take a maximum load every time.

1



1. EFFICIENCY.

Compact parking position.

2. INTERNAL ROUTING. Hoses and pipes protected through internal routing throughout the boom system.

3. COMPACT. Hoses and pipes also protected throughout the crane column.

4. LEADING REACH. One of few cranes with an entire 10.5 meter reach.

2



3



4

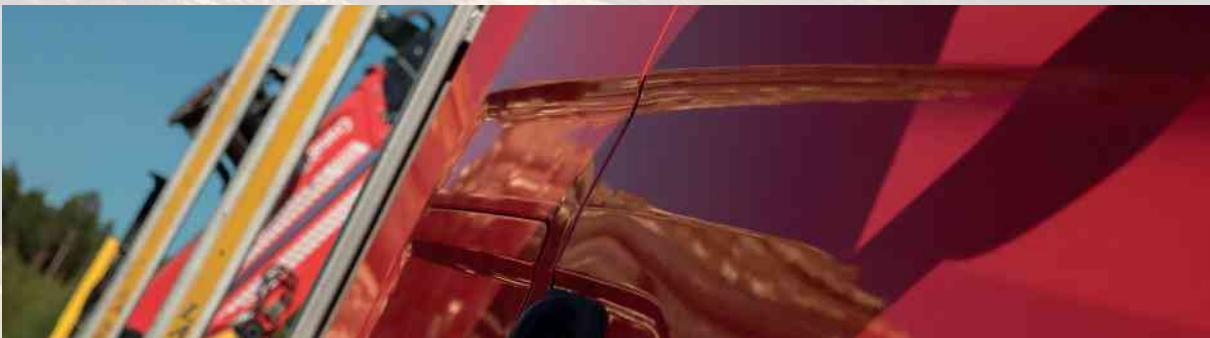
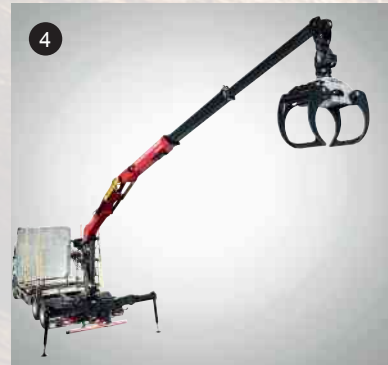

ENGINEERED AND DEVELOPED FOR THE TOUGHEST JOBS

Cranab's truck cranes put you one step ahead: They are designed to be strong, robust and powerful. The cranes are built based on a proven and safe technology, which is both modern and efficient. Significant emphasis has been put into the cranes being operationally reliable, dependable and service-friendly.



1. TORQUE LINKAGE. Link between the pillar and boom for increased power in critical situations. The power link means uniform movement and speed right across the working range, which equates to good operating characteristics close up.

2. INCREASED SPEED. 1/2" hoses and pipes to the grapple throughout the boom system. A solution unique to Cranab's cranes.

3. DOUBLE SLEWING SYSTEM. End position damping for the slew function. This means gentler stops at the end position.

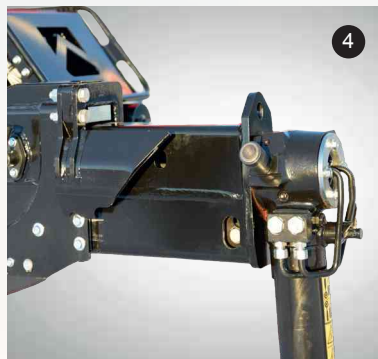

4. PROTECTED STABILIZER LEG BEAM. Internal hose routing in the stabilizer leg beam for beam widening and stabilizer leg cylinders at a 45 degree retraction. Also available with external hose routing.

5. SLEWING MOTOR. Slewing motor with double slewing systems, with a 425 degree slewing angle. Details adapted from forestry forwarder technology.

6. THREE-POINT YOKE. Secure stabilizer beam with three-point yoke to counteract torsion in the truck chassis.

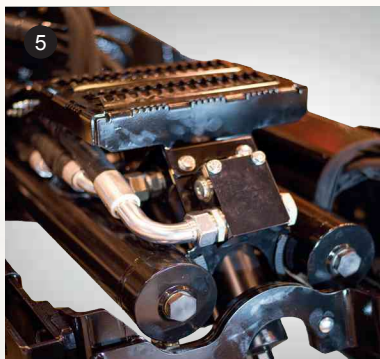

7. PINS OF THE HIGHEST CLASS. Generously dimensioned and holed pins – nitrocarburized for improved durability and corrosion protection. Low friction means reduced wear on bushings.



OPEN OPERATOR'S POSITION



1. SIDE MOUNTED. A side-mounted operator's position gives the best possible overview of specific applications.

2. CENTRE-MOUNTED. The open operator's position is comfortable, ergonomic operator's position with a tight rotation area.

3. CANOPY. The open operator's position can be fitted with a crane canopy as a practical and safe protection against strong sunlight, rain, snow or wind.

OPERATOR'S CAB



1. OPERATOR'S CAB. The cab is spacious, bright and well ventilated. It can be configured according to requirements. Water or diesel heater and AC are optional extras. The cab affords a very agreeable working environment.

2. CAB FOR ELECTRICAL OPERATION. Cab for electrically-operated crane.

3. CAB FOR MECHANICAL OPERATION. Cab for mechanically-operated crane.

COMMON FUNCTIONS

1. **LCD.** Distinct screen displaying, inter alia, crane settings for electrically-operated cranes.
2. **JOYSTICK.** Ergonomic joystick with buttons for versatile crane operation.
3. **MECHANICAL CRANE OPERATION.** 2+2 control, alternatively 4+2 control.
4. **ACTIVATION LOCK.** Safety device when operating the stabilizer leg valve.
5. **CONTROL BOX.** Operation of, inter alia, stabilizer leg valve from the operator's position.
6. **PANEL.** Distinct buttons inside the cab.
7. **RADIO CONTROL.** Operate crane by radio.

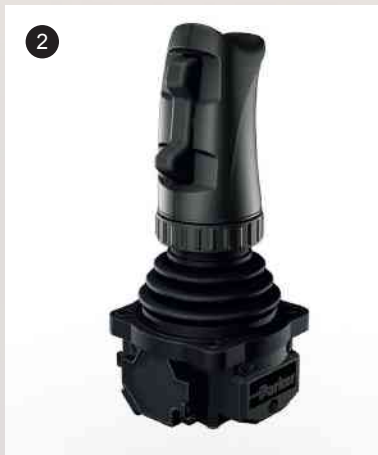

CE KIT FOR FORESTRY WORK

- Sensor for stabilizer beam's parking position.
- Sensor for main boom position.
- Overload indicator.
- Position indicator.
- Hose breach valve for lift function.
- Emergency stop.
- Seat sensor.

CE KIT FOR RECYCLING WORK

- Sensor for parking position and operating position.
- Sensor for stabilizer leg cylinder, lower.
- Sensor for main boom position.
- Pilot-controlled check valve for lift arm and boom.
- Stability control for monitoring and stability.
- Sensor for slewing position.
- Position indicator.



1. PILOT-CONTROLLED CHECK VALVE.

Safety system for recycling work. For safe crane operation.

2. STABILITY CONTROL.

For monitoring stability.

3. SLEWING POSITION.

Sensor for slewing position.

SELECT FEATURES FOR YOUR SPECIFIC NEEDS

Because it's important to us that your truck crane lives up to your expectations. We make certain you get the best possible support before you make a decision. There are many options, and together we're able to tailor a solution that's perfect for your own specific requirements and needs. You call the shots.

1. STABILIZER RETRACTION.

180° stabilizer retraction with external hose runs.

2. VERTICAL EXTENSION. Extension by 30, 45 or 60 degrees.

3. STABILIZER LEG VALVE.

Electrically/manually operated stabilizer

leg valve. 4-6-8 sections adapted to 1-circuit, 2-circuit and LS systems.

4. LIGHTING OPTIONS. Work lights on front of boom and operator's position. Rear-facing lights available. Choose between halogen and LED.

5. WEIGHT LINKAGE. Weighing linkage

at crane nose senses the weight of the load in the grapple.

6. ROTATORS. Other rotator and link options, all with protected hose routings.

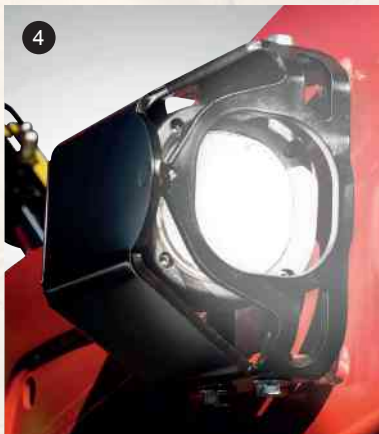
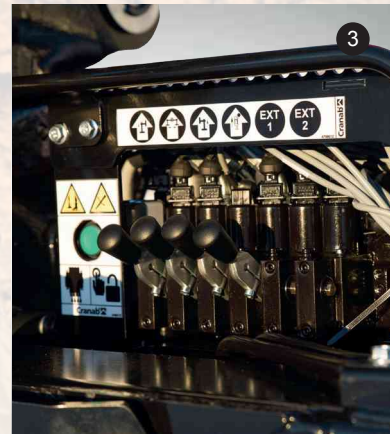
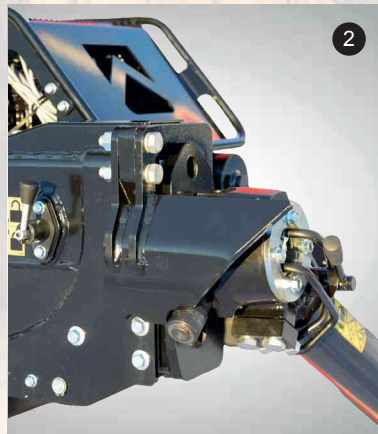
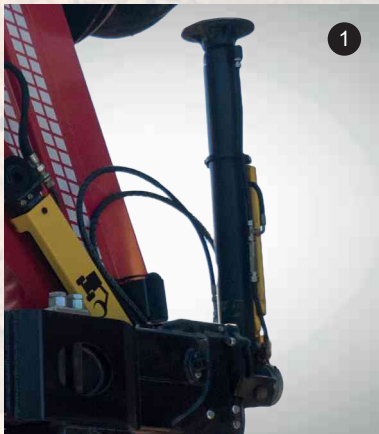

OPTIONS

- Crane cab with mounting position as required. Purchaser chooses between cab or open operator's position.
- Canopy/rain shelter for open operator's position.
- Heated seat for open operator's position.
- Work lights on front of boom and around operator's position. Choose between halogen and LED.
- Crane arm and boom available in other colours. Standard colour is red.
- Motor start/stop and rpm control.
- Extension of stabilizer leg, 30, 45, 60 or 180 degrees.
- Internal hose routing inside the stabilizer beam.
- Rotator and linkage options, all with protected hose routings.
- Weighing link with radio transmission to digital scales.
- Grapple.
- Consoles for crane installation.
- Installation bolts M30x1.5.

OPEN OPERATOR'S POSITION, TZ/TL

Right-hand mounted sitting position

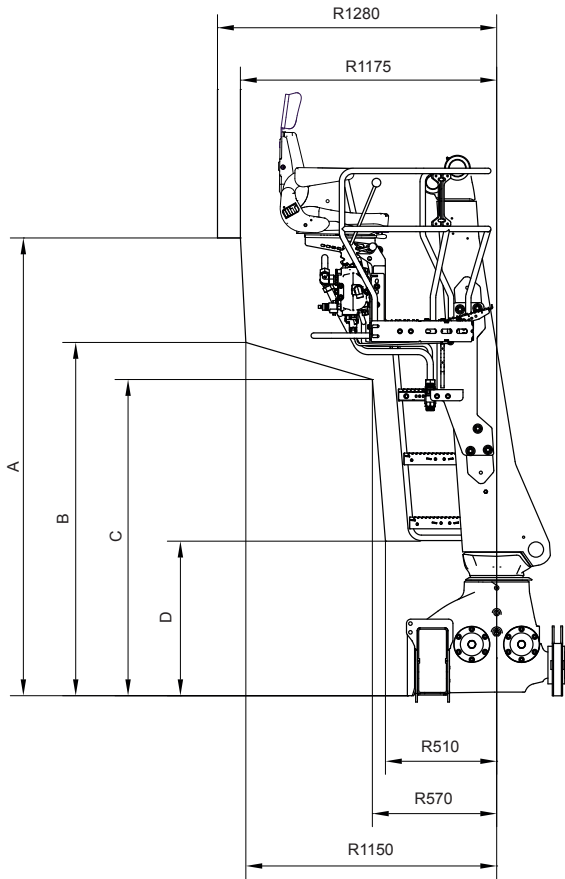

Centre-mounted sitting position

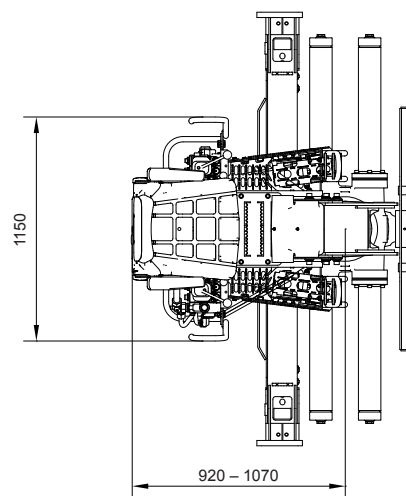
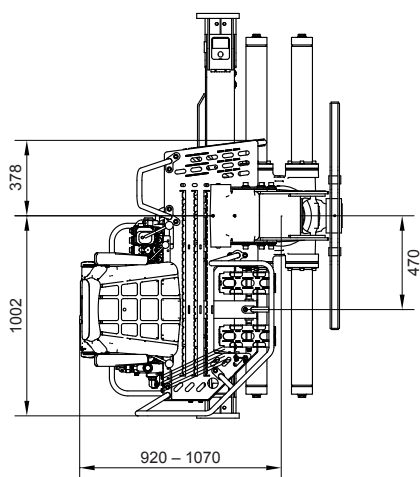
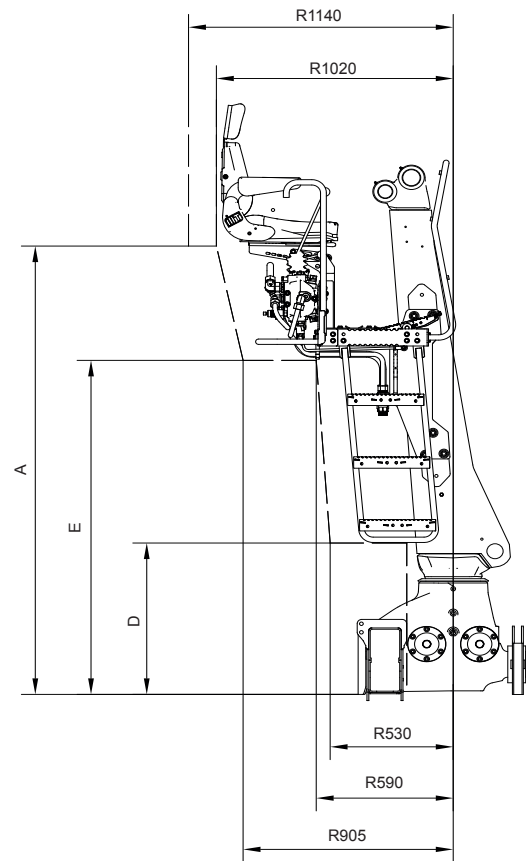

	A	B	C	D	E
TZ	2099 mm	1620 mm	1450 mm	709 mm	1564 mm
TL	1926 mm	1447 mm	1277 mm	789 mm	1391 mm

CAB, TZ/TL

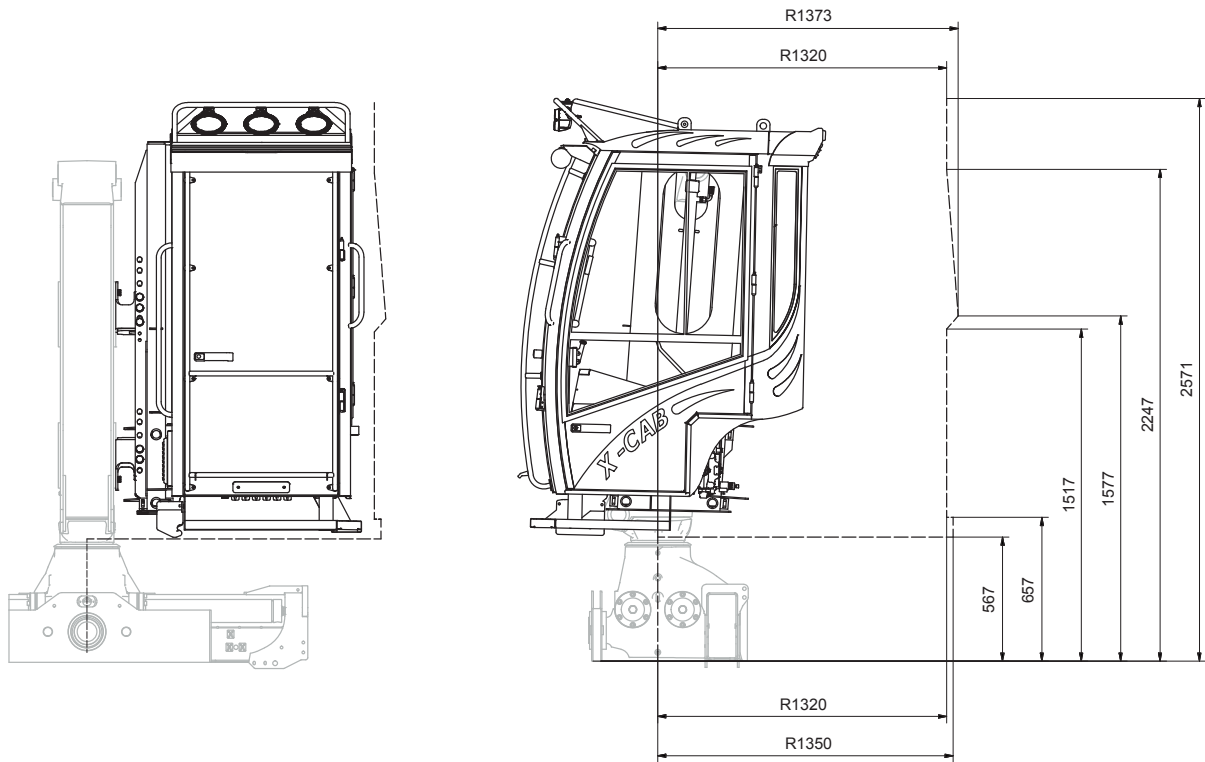

MOUNTING DIMENSION

Left position of pillar

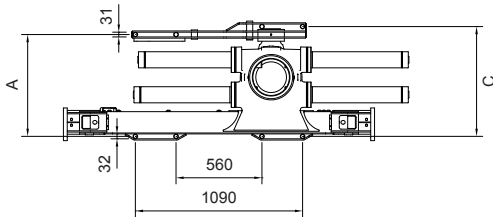

Right position of pillar

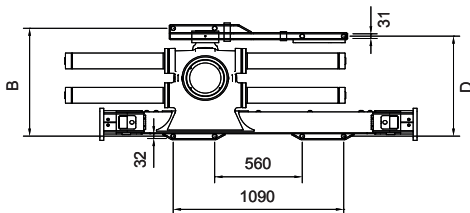

Centre position of pillar

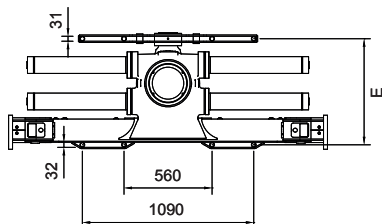

Three-point yoke. Left- and right position of pillar

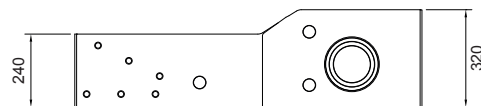

Three-point yoke. Centre position of pillar

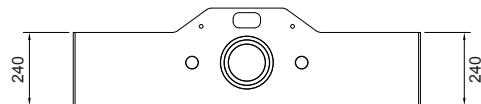

Stabilizer beam height

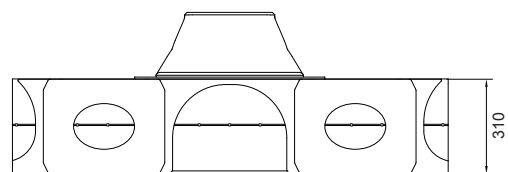

	A	B	C	D	E
3,9m base	663 mm	715 mm	715 mm	663 mm	663 mm
5,1m base	796 mm	848 mm	848 mm	796 mm	796 mm

TL12

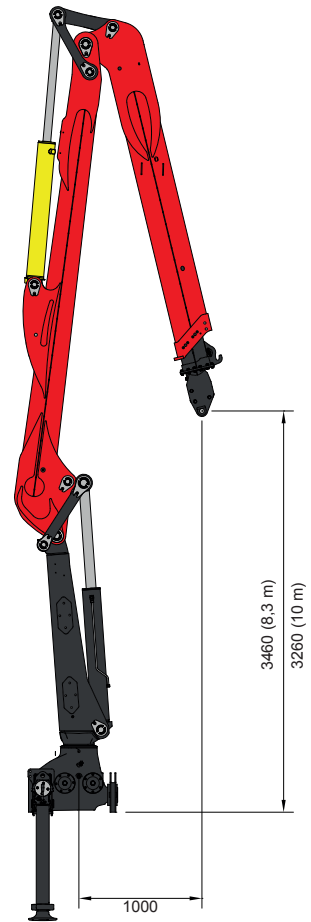
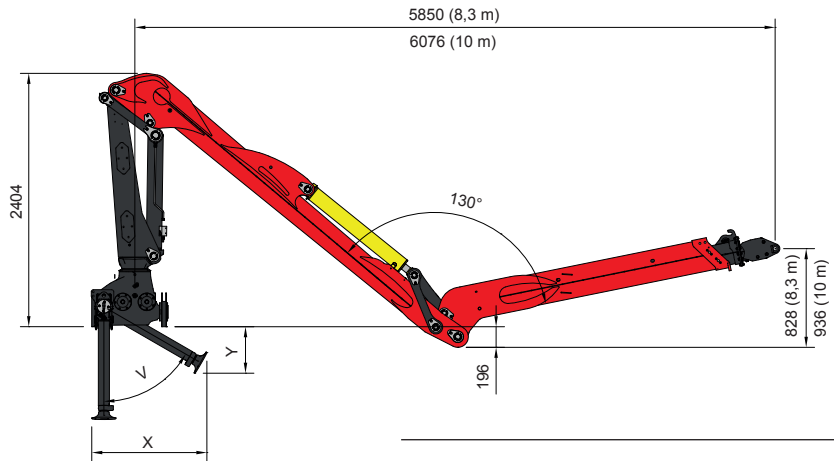
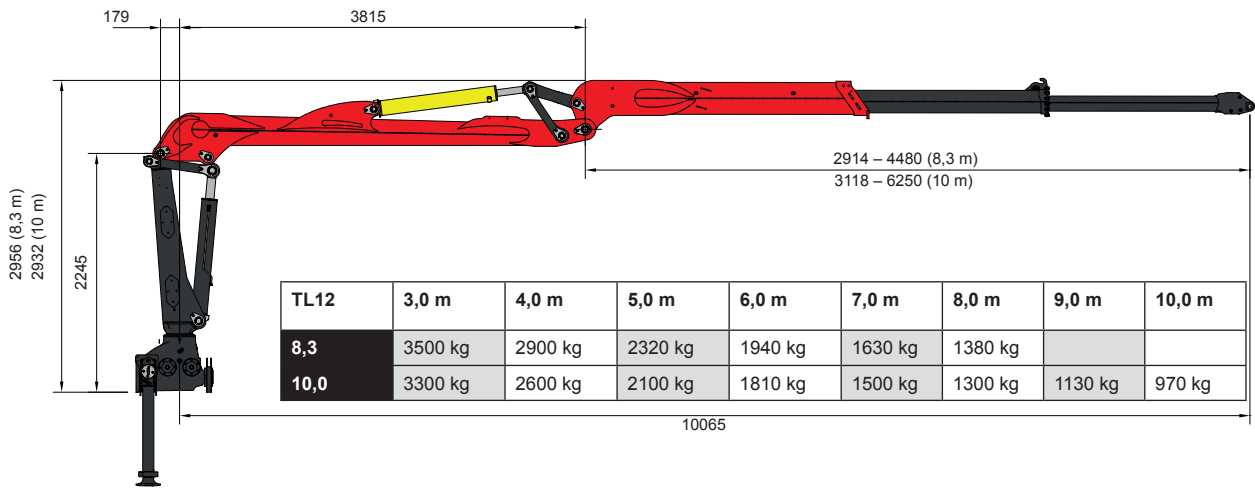

L1	L2	V	X	Y	Z
880	670	0°	-	-	2530
880	670	30°	743	789	2525
880	670	45°	945	640	2510
880	670	60°	1085	440	2489
960	750	0°	-	-	2550
960	750	30°	782	858	2530
960	750	45°	1000	700	2515
960	750	60°	1160	480	2490

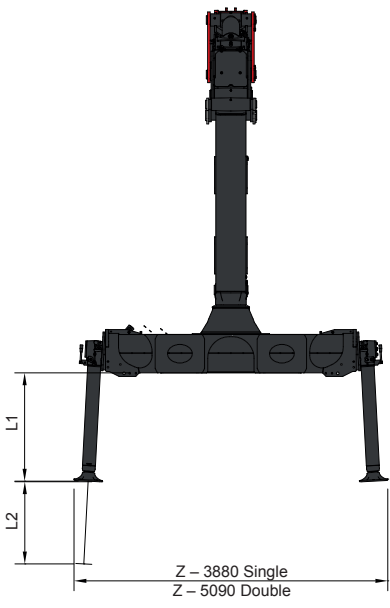

TL12										
8,3	115 kNm	8,3 m	1,57 m	425°	29,3	26	120-160	80-100	2 x 70	2415 kg*
10,0	106,4 kNm	10,0 m	3,1 m	425°	29,3	26	120-160	80-100	2 x 70	2535 kg*

* = Weight with top seat. TL12 with cab 8,3 m = 2815 kg; 10 m 2935 kg.

TZ12

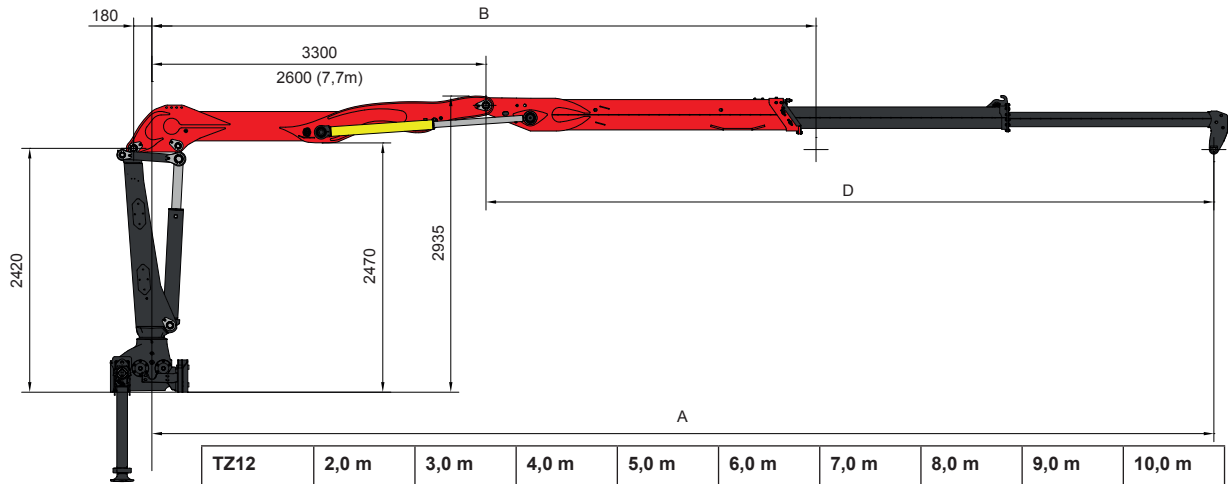

TZ12	2,0 m	3,0 m	4,0 m	5,0 m	6,0 m	7,0 m	8,0 m	9,0 m	10,0 m
7,7	4500 kg	3200 kg	2570 kg	2200 kg	1830 kg	1530 kg			
8,3		3090 kg	2390 kg	2005 kg	1750 kg	1510 kg	1300 kg		
9,3		3080 kg	2380 kg	1930 kg	1730 kg	1470 kg	1260 kg	1100 kg	
10,5		2880 kg	2250 kg	1870 kg	1650 kg	1430 kg	1230 kg	1050 kg	900 kg

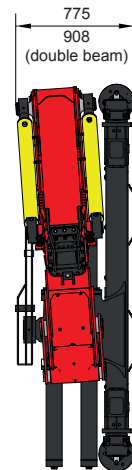
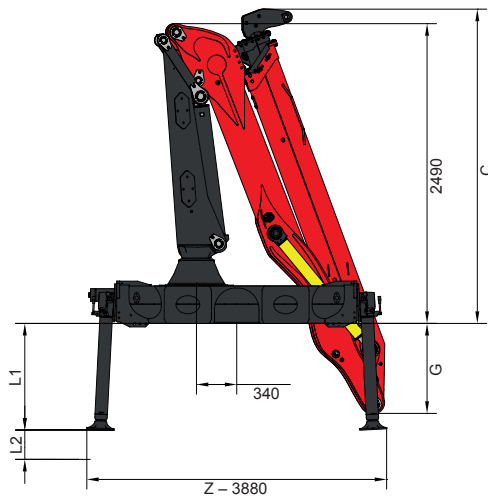
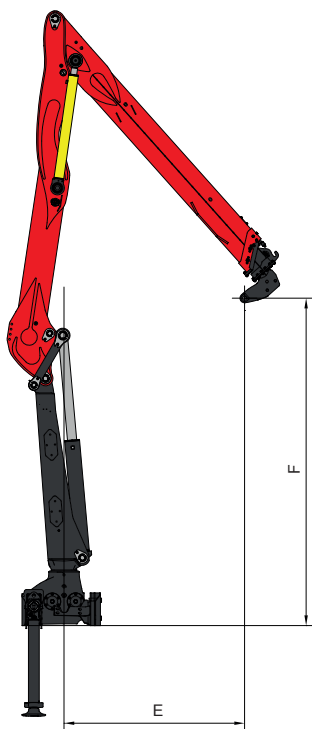

TZ12	A	B	C	D	E	F	G
7,7	7700	5134	2650	2562-5094	1189	3029	85
8,3	8315	6347	2380	3047-5013	1685	3420	735
9,3	9300	6165	2240	2862-5994	1495	3500	735
10,5	10500	6565	2610	3262-7195	1760	3200	735

TZ12										
7,7	110,5 kNm	7,7 m	2,53 m	425°	29,3	26	120-160	80-100	2 x 70	2450 kg*
8,3	108 kNm	8,3 m	1,97 m	425°	29,3	26	120-160	80-100	2 x 70	2425 kg*
9,3	102,8 kNm	9,3 m	3,1 m	425°	29,3	26	120-160	80-100	2 x 70	2475 kg*
10,5	99,7 kNm	10,5 m	3,9 m	425°	29,3	26	120-160	80-100	2 x 70	2515 kg*

* = Weight with top seat. TZ12 with cab 7,7 m = 2850 kg; 8,3 m = 2825 kg; 9,3 m = 2875 kg; 10,5 m = 2915 kg.



EXPERIENCE. TECHNOLOGY. INNOVATION.

Cranab's factories are located in Vindeln, deep in the forests of West Bothnia. Here we develop and manufacture world-class cranes, grapples and land clearing machines. We are driven by a genuine passion for forestry and road clearance technology. We are also driven by an unyielding commitment to constantly push technology development forwards. Although we are based in northern Sweden, we reach out to the whole world to be close to the customers we develop products for. We listen carefully to their requirements and draw on more than 50 years of experience and solid technological expertise to develop innovative products.

Experience, technological expertise and an unswerving determination to improve. This is a somewhat ingenious combination if you ask us.

Cranab Slagkraft is part of the CRANAB GROUP, which also includes Vimek and Bracke Forest. Today, the companies are world-leaders in their respective fields. Our common success factors are the development, manufacture and marketing of the best technical solutions for forestry and road clearance work.